

Product Technical Data Sheet

Multigrip Rivets Aluminium Body Steel Mandrel

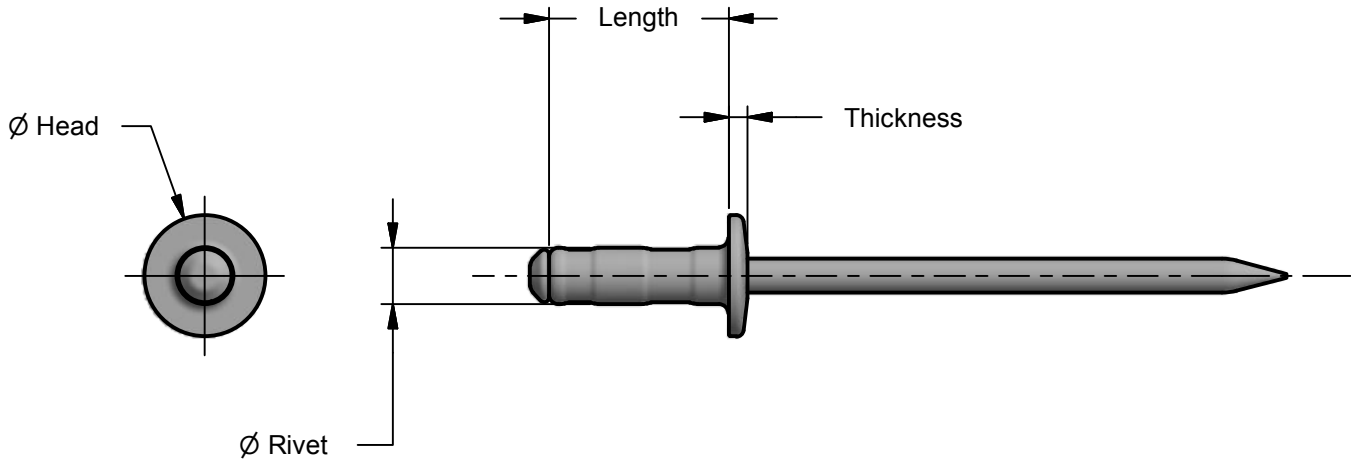

Description	Rivet Dia	Length	Grip Range	Head Dia	Thickness	Hole Size
ABMG 4-1/3	1/8" (3.2 mm)	8.0	0.8 ~ 4.8	6.4	1.2 Max	3.3 ~ 3.4 (# 30 Drill)
ABMG 5-1/3	5/32" (4.0mm)	8.0	0.8 ~ 4.8	7.9	1.5 Max	4.1 ~ 4.2 (# 20 Drill)

All dimensions nominal unless otherwise stated. Normal manufacturing tolerances apply. All dimensions in millimeters.
Third Angle Projection. Scale: 2.5 x Full Size

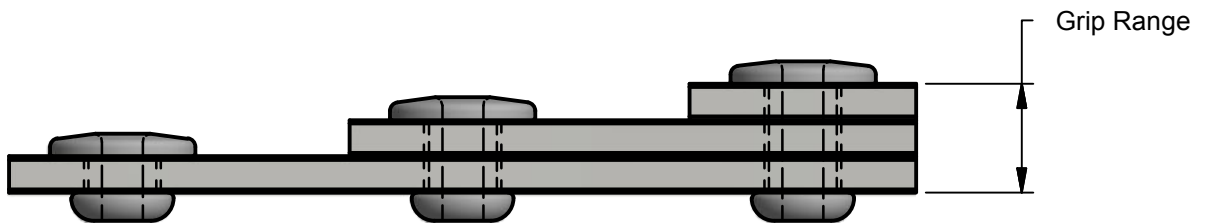

Buildex® Head Office
600 South Road
Moorabbin Victoria 3189
Australia

1300 368 101
CustomerService-MBN@buildex.com.au

Technical Help Desk
Technicalhelpdesk@buildex.com.au