

Product Technical Data Sheet

10-16 Flat Csk with Ribs Wing TekS Climacoat

Part Number	Description	Pack Qty	Pallet Qty
6-321-0040-7CC	10-16 x 45 Flat Countersunk with Ribs Wing TekS Climacoat	500 / 2000	144,000
6-321-0042-3CC	10-16 x 55 Flat Countersunk with Ribs Wing TekS Climacoat	1000	105,000
6-321-0043-1CC	10-16 x 75 Flat Countersunk with Ribs Wing TekS Climacoat	1000	84,000

Application:

Buildex® 10 -16 Flat Csk with Ribs WingTekS® Screw is used for fixing timber floor, fences and composite boards to metal.

Drilling and Installing Capacity:

Refer sheet 2.

Features:

Underhead Teeth

Teks® Point

WingTekS®

Benefits:

For counter-sinking the head into the timber or composite board.

For drilling into steel while ensuring maximum pullout strength and a high strip torque.

Removes the need for pre drilling the timber or composite board.

Installation Instructions:

1. Use a Number 2 Phillips Driver Bit
2. Use a mains powered or cordless screw driver with a 3,000 RPM speed.
3. Fit the Number 2 Phillips Driver Bit into the screw and place at the fastening position.
4. Apply consistently firm pressure (end load) to the screw driver until the screw has fastened.

Material: Carbon Steel SAE 1022 | **Heat Treatment:** To AS 3566.1 | **Finish:** Climacoat

Mechanical Properties:

Single Shear Strength (Newton) 6,000 | Axial Tensile (Newton) 12,000 | Torsion Strength 8.5 Newton-metre

Pullout Values (N):

1.2 mm G450 Steel Purlin: 2,320 | 1.5 mm G450 Steel Purlin: 4,200 | 1.9 mm Steel Purlin: 5,500 | 2.4 mm G450 Steel Purlin: 7,820

All values are averages obtained under laboratory conditions and appropriate safety factors should be applied for design purposes.

These figures are applicable to Buildex® head marked product only.

Corrosion Performance:

The 10 -16 Flat Csk with Ribs WingTekS® Screw complies to 1000 Hours Salt Spray Testing when tested in accordance to AS 2331.3.1

Product Technical Data Sheet

10-16 Flat Csk with Ribs Wing Tek Climacoat

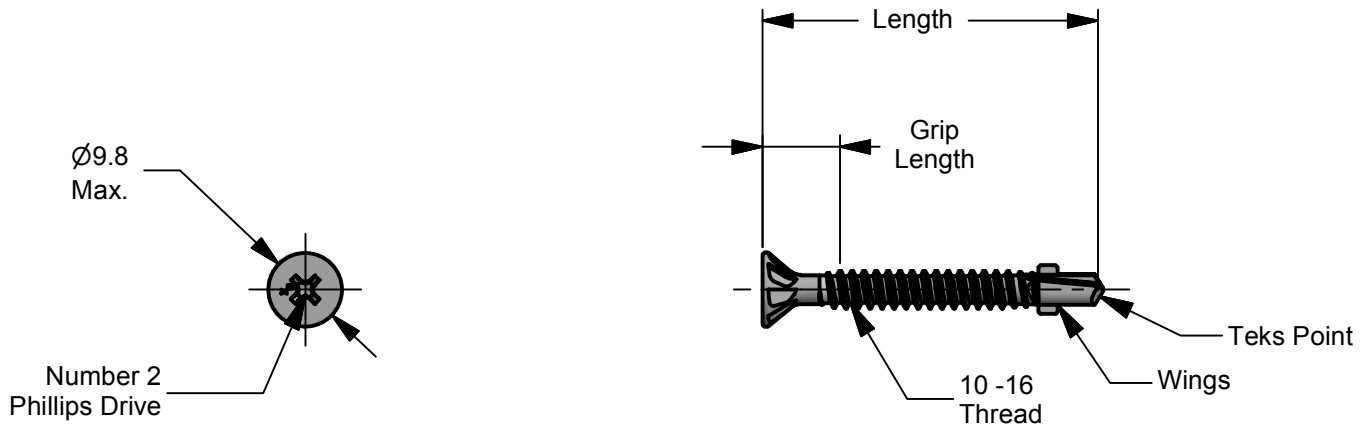

Part Number	Description	Length	Grip Length
6-321-0040-7CC	10-16 x 45 Flat Countersunk with Ribs Wing Tek Climacoat	44.0 / 46.0	10.75 Max.
6-321-0042-3CC	10-16 x 55 Flat Countersunk with Ribs Wing Tek Climacoat	54.0 / 56.0	10.75 Max.
6-321-0043-1CC	10-16 x 75 Flat Countersunk with Ribs Wing Tek Climacoat	74.0 / 76.0	30.75 Max.

All dimensions nominal unless otherwise stated. Normal manufacturing tolerances apply. All dimensions in millimeters. Third Angle Projection. Scale Full Size

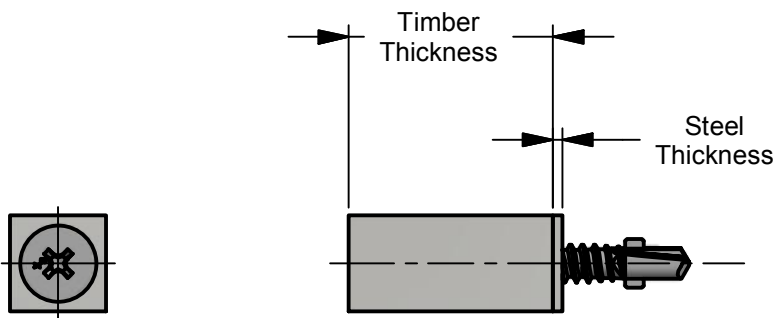

Part Number	Timber Thickness	Steel Thickness
6-321-0040-7CC	11.0 mm ~ 27.0 mm.	1.2 mm / 3.5 mm
6-321-0042-3CC	11.0 mm ~ 37.0 mm	1.2 mm / 3.5 mm
6-321-0043-1CC	31.0 mm ~ 57.0 mm	1.2 mm / 3.5 mm

Buildex® Head Office
 600 South Road
 Moorabbin Victoria 3189
 Australia

1300 368 101
 CustomerService-MBN@buildex.com.au

Technical Help Desk
 Technicalhelpdesk@buildex.com.au